

Data sheet

Shut-off ball valve for high pressure

Type GBCT for transcritical R744 / CO₂ (140 bar / 2031 psig)

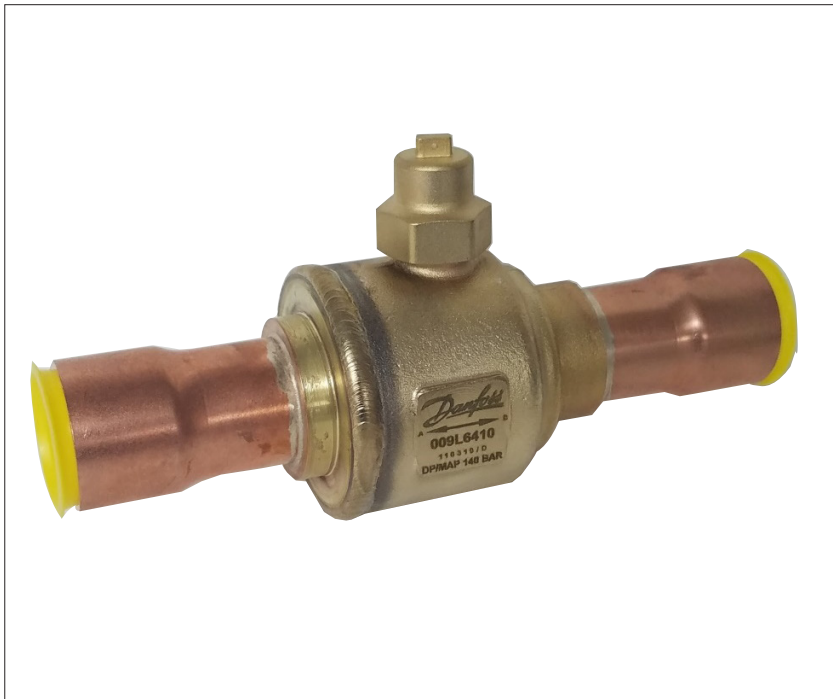

Danfoss shut-off ball valves, type GBCT for R744 (CO₂) high pressure are manually operated shut-off valves for transcritical CO₂ refrigeration systems, in order to open and to shut off inner flow path by operating the valve spindle.

The valve structure and materials are designed and tested specifically for use with CO₂ refrigerant. The valves are approved for use in transcritical CO₂ refrigeration systems.

Features

- Designed for transcritical CO₂ systems
- Design Pressure (DP)/ Maximum abnormal pressure (MAP): 140 bar / 2031 psig
- Continuous operating temperature (COT): -40 °C – 149 °C / -40 °F – 300 °F
- Bi-directional flow
- UL/cUL Listed, complies with Pressure Equipment Directive 2014/68/ EU
- Full port construction to match line size
- Rupture proof, internally-loaded spindle design ensures safe operation under extreme pressures
- Specially-selected sealing material for CO₂ refrigerant
- Reinforced copper-iron tube extensions permit trouble-free valve installation with traditional torch-brazing methods
- Optimized internal seal interface provides shut-off in both directions under high pressure differentials

Approvals

Technical data

Refrigerants	R 744 (CO ₂)
Oils:	POE, PAG
Continuous operating temperature (COT)	-40 °C – 149 °C / -40 °F – 300 °F
Design Pressure (DP)/ Maximum abnormal pressure (MAP)	140 bar / 2031 psig
Flow direction	bi-flow

CAUTION - RISK OF HIGH PRESSURE

Do not close with CO₂ liquid temperature below ambient. This component shall be installed along with a pressure relief valve set to discharge at no higher than the rated pressure of this component. This component is intended for systems in which the critical pressure of the refrigerant will be exceeded. The relief valve shall comply with the requirements of ASME Section VIII, be marked "UV" and sized based on the refrigeration system capacity.

Notes: For the application use with R744 as part of a secondary loop or cascade:

1. The design pressure of the refrigerant containing component is not less than the design pressure of the associated components.
2. The component is not provided with any pressure relief or pressure regulating relief valve and that a sufficient number of valves having capacity deemed adequate shall be field-installed on the refrigeration system.
3. When the refrigeration system is de-energized, venting of R744 may occur through the pressure regulating relief valves, and may need to be recharged, but the valve should not be defeated or bypassed.
4. A sufficient number of pressure relief and pressure regulating valves may need to be provided based upon system capacity and located such that no stop valve is provided between the relief valve and the parts or section of the system being protected.

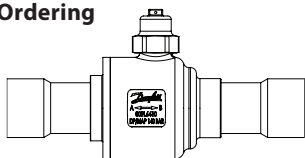
Ordering

GBCT without access port

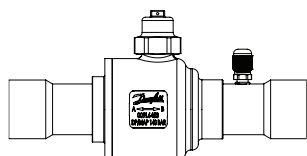
Type	Size	K _v value [m ³ /h]	C _v value [gal/min]	Multi pack [Pcs. per pack]	Code no.
	[inch]				
GBCT 6s	1/4	0.9	1.0	30	009L6415
GBCT 10s	3/8	3.7	4.3	30	009L6416
GBCT 12s	1/2	5.4	6.2	30	009L6417
GBCT 16s	5/8	10.4	12.1	30	009L6418
GBCT 18s	3/4	16.4	19.0	5	009L6419
GBCT 22s	7/8	23.7	27.5	5	009L6420
GBCT 28s	1 1/8	42.3	48.9	5	009L6406
GBCT 35s	1 3/8	67.1	77.6	5	009L6410
GBCT 42s	1 5/8	83.1	96.1	4	009L6411
GBCT 54s	2 1/8	171.3	198.0	2	009L6412

GBCT with access port

Type	Size	K _v value [m ³ /h]	C _v value [gal/min]	Multi pack [Pcs. per pack]	Code no.
	[inch]				
GBCT 6s	1/4	0.9	1.0	30	009L6581
GBCT 10s	3/8	3.7	4.3	30	009L6582
GBCT 12s	1/2	5.4	6.2	30	009L6585
GBCT 16s	5/8	10.4	12.1	30	009L6586
GBCT 18s	3/4	16.4	19.0	5	009L6588
GBCT 22s	7/8	23.7	27.5	5	009L6589
GBCT 28s	1 1/8	42.3	48.9	5	009L6451
GBCT 35s	1 3/8	67.1	77.6	5	009L6453
GBCT 42s	1 5/8	83.1	96.1	4	009L6454
GBCT 54s	2 1/8	171.3	198.0	2	009L6456

Design / Function

1. Copper-Iron extension tubes
2. Valve body
3. Ball seat (PTFE)
4. Valve tail
5. Stainless steel ball
6. Double O-ring seal in spindle
7. Cap seal (PTFE)
8. Seal cap
9. Spindle
10. Pin
11. Guide ring
12. Valve core

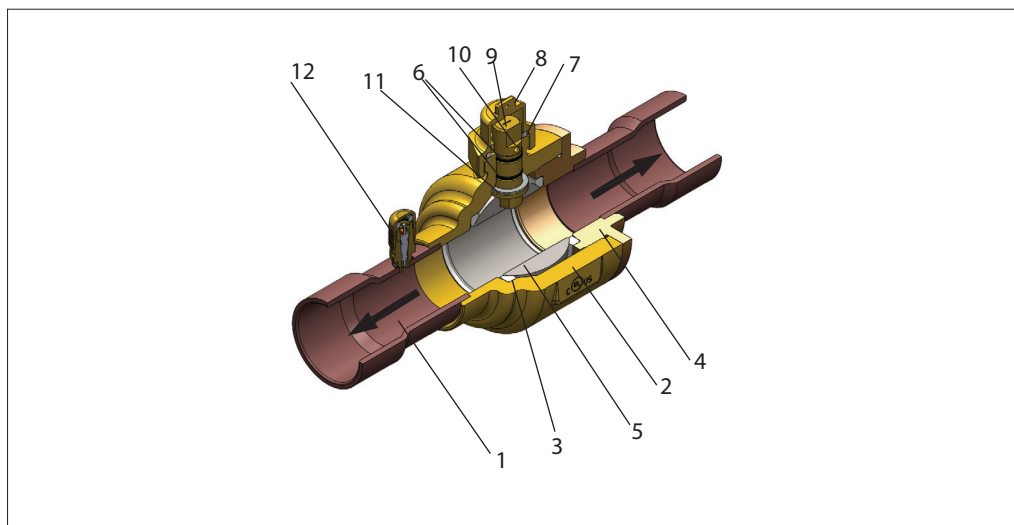

Dimensions and weights

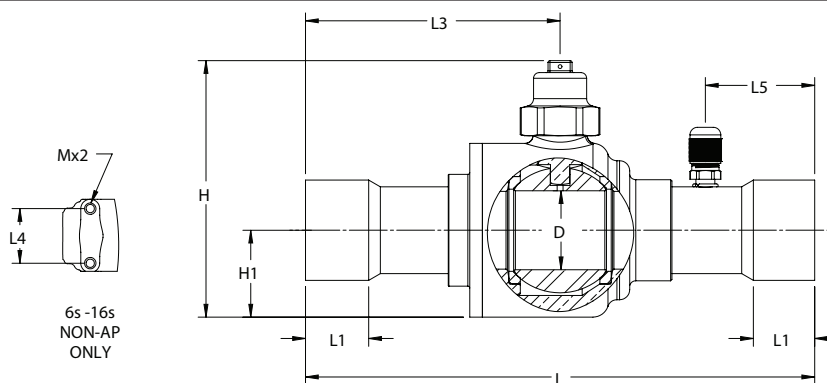

SI units

Type	Connection [inch]	Access port	H [mm]	H1 [mm]	L [mm]	L1 MIN [mm]	L3 [mm]	L4 [mm]	L5 [mm]	M [mm]	D [mm]	Weight [Kg]	Code no.
GBCT 6s	1/4	No	57	14	127	6.4	70	22	N/A	M4 x 0.7	13	0.21	009L6415
GBCT 10s	3/8	No	57	14	132	7.9	72	22	N/A	M4 x 0.7	13	0.22	009L6416
GBCT 12s	1/2	No	57	14	139	9.7	75	22	N/A	M4 x 0.7	13	0.22	009L6417
GBCT 16s	5/8	No	57	14	148	12.7	80	22	N/A	M4 x 0.7	13	0.23	009L6418
GBCT 18s	3/4	No	87	32	148	15.7	78	N/A	N/A	N/A	19	0.66	009L6419
GBCT 22s	7/8	No	87	32	185	19.1	97	N/A	N/A	N/A	19	0.68	009L6420
GBCT 28s	1 1/8	No	102	37	185	23.1	96	N/A	N/A	N/A	25	1.31	009L6406
GBCT 35s	1 3/8	No	103	35	205	24.6	103	N/A	N/A	N/A	32	1.95	009L6410
GBCT 42s	1 5/8	No	113	40	240	27.7	120	N/A	N/A	N/A	38	2.93	009L6411
GBCT 54s	2 1/8	No	144	52	275	34.0	137	N/A	N/A	N/A	51	6.07	009L6412

Type	Connection [inch]	Access port	H [mm]	H1 [mm]	L [mm]	L1 MIN [mm]	L3 [mm]	L4 [mm]	L5 [mm]	M [mm]	D [mm]	Weight [Kg]	Code no.
GBCT 6s	1/4	Yes	57	14	127	6.4	55	N/A	44	N/A	13	0.27	009L6581
GBCT 10s	3/8	Yes	57	14	132	7.9	58	N/A	46	N/A	13	0.27	009L6582
GBCT 12s	1/2	Yes	57	14	139	9.7	61	N/A	50	N/A	13	0.28	009L6585
GBCT 16s	5/8	Yes	57	14	148	12.7	66	N/A	54	N/A	13	0.28	009L6586
GBCT 18s	3/4	Yes	87	32	148	15.7	78	N/A	30	N/A	19	0.67	009L6588
GBCT 22s	7/8	Yes	87	32	185	19.1	97	N/A	40	N/A	19	0.70	009L6589
GBCT 28s	1 1/8	Yes	102	37	185	23.1	96	N/A	40	N/A	25	1.32	009L6451
GBCT 35s	1 3/8	Yes	103	35	205	24.6	103	N/A	44	N/A	32	1.96	009L6453
GBCT 42s	1 5/8	Yes	113	40	240	27.7	120	N/A	50	N/A	38	2.94	009L6454
GBCT 54s	2 1/8	Yes	144	52	275	34.0	137	N/A	56	N/A	51	6.09	009L6456

Dimensions and weights

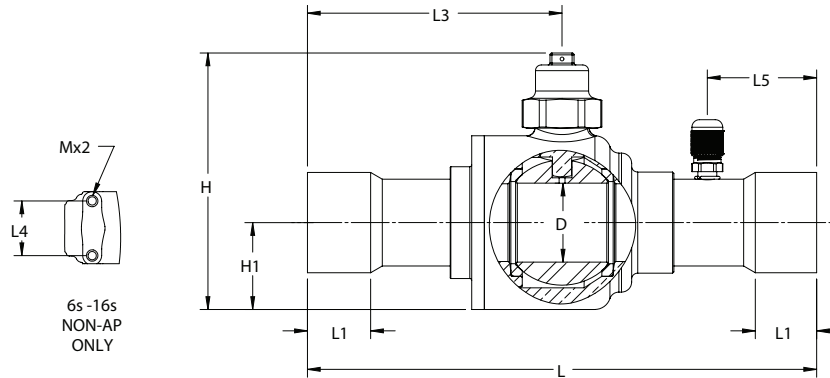

US units

Type	Connection [inch]	Access port	H	H1	L	L1 MIN	L3	L4	L5	M	D	Weight	Code no.
			[inch]	[inch]	[inch]	[inch]	[inch]	[inch]	[inch]	[inch]	[mm]	[inch]	
GBCT 6s	1/4	No	2.2	0.6	5.0	0.25	2.8	0.9	N/A	M4 x 0.7	0.5	0.47	009L6415
GBCT 10s	3/8	No	2.2	0.6	5.2	0.31	2.8	0.9	N/A	M4 x 0.7	0.5	0.48	009L6416
GBCT 12s	1/2	No	2.2	0.6	5.5	0.38	3.0	0.9	N/A	M4 x 0.7	0.5	0.49	009L6417
GBCT 16s	5/8	No	2.2	0.6	5.8	0.50	3.1	0.9	N/A	M4 x 0.7	0.5	0.50	009L6418
GBCT 18s	3/4	No	3.4	1.3	5.8	0.62	3.1	N/A	N/A	N/A	0.7	1.46	009L6419
GBCT 22s	7/8	No	3.4	1.3	7.3	0.75	3.8	N/A	N/A	N/A	0.7	1.51	009L6420
GBCT 28s	1 1/8	No	4.0	1.5	7.3	0.91	3.8	N/A	N/A	N/A	1.0	2.89	009L6406
GBCT 35s	1 3/8	No	4.1	1.4	8.1	0.97	4.1	N/A	N/A	N/A	1.3	4.29	009L6410
GBCT 42s	1 5/8	No	4.4	1.6	9.4	1.09	4.7	N/A	N/A	N/A	1.5	6.46	009L6411
GBCT 54s	2 1/8	No	5.7	2.0	10.8	1.34	5.4	N/A	N/A	N/A	2.0	13.39	009L6412

Type	Connection [inch]	Access port	H	H1	L	L1 MIN	L3	L4	L5	M	D	Weight	Code no.
			[inch]	[inch]	[inch]	[inch]	[inch]	[inch]	[inch]	[inch]	[mm]	[inch]	
GBCT 6s	1/4	Yes	2.2	0.6	5.0	0.25	2.2	N/A	1.7	N/A	0.5	0.59	009L6581
GBCT 10s	3/8	Yes	2.2	0.6	5.2	0.31	2.3	N/A	1.8	N/A	0.5	0.60	009L6582
GBCT 12s	1/2	Yes	2.2	0.6	5.5	0.38	2.4	N/A	2.0	N/A	0.5	0.61	009L6585
GBCT 16s	5/8	Yes	2.2	0.6	5.8	0.50	2.6	N/A	2.1	N/A	0.5	0.62	009L6586
GBCT 18s	3/4	Yes	3.4	1.3	5.8	0.62	3.1	N/A	1.2	N/A	0.7	1.49	009L6588
GBCT 22s	7/8	Yes	3.4	1.3	7.3	0.75	3.8	N/A	1.6	N/A	0.7	1.54	009L6589
GBCT 28s	1 1/8	Yes	4.0	1.5	7.3	0.91	3.8	N/A	1.6	N/A	1.0	2.92	009L6451
GBCT 35s	1 3/8	Yes	4.1	1.4	8.1	0.97	4.1	N/A	1.7	N/A	1.3	4.32	009L6453
GBCT 42s	1 5/8	Yes	4.4	1.6	9.4	1.09	4.7	N/A	2.0	N/A	1.5	6.49	009L6454
GBCT 54s	2 1/8	Yes	5.7	2.0	10.8	1.34	5.4	N/A	2.2	N/A	2.0	13.42	009L6456

Danfoss can accept no responsibility for possible errors in catalogues, brochures and other printed material. Danfoss reserves the right to alter its products without notice. This also applies to products already on order provided that such alterations can be made without consequential changes being necessary in specifications already agreed. All trademarks in this material are property of the respective companies. Danfoss and the Danfoss logotype are trademarks of Danfoss A/S. All rights reserved.